

# Series 1900



**EAGLESTONE**  
EQUIPMENT

## Series 1900 Flip Clean Conveyor

### FEATURES

Made in the USA  
304 stainless steel construction  
Extreme wash down  
Severe duty gear motor

### DESIGN HIGHLIGHTS

Food-safe applications  
Flip clean in-feed end  
Very quiet operation  
Few spare parts  
Fast & easy cleaning  
Low operating cost  
Long lasting design

### OPTIONS

Nema 4X VFD  
Side guides  
Full welded model  
Stainless motor and reducer  
UHMW-PE side guides  
S.S. Casters

Eaglestone Inc.  
3705 Swenson Ave.  
St. Charles, IL 60174

Tel: 630-587-1115  
Fax: 630-587-1116  
Email: [cs@eaglestoneinc.com](mailto:cs@eaglestoneinc.com)

[www.EaglestoneEquipment.com](http://www.EaglestoneEquipment.com)



- Tool less belt removal.
- Solid Urethane belts.
- Shown with optional cantilever designed frame.
- Full welded food grade seams.

Eaglestone Equipment knows the challenges of sanitation for the food service professional. With the constant concern of bacteria growth, inspections, and proper food handling; conveyors should be a help, not a hindrance. This is why we developed the 1900 flip clean conveyor. With the tool less flip clean end, you can easily remove the tension from the belt and either clean in place or remove the entire belt for sanitation.



Easily remove belt for sanitation.



**EAGLESTONE**  
EQUIPMENT

# Series 1900



# EAGLESTONE

EQUIPMENT

## Series 1900 Flip Clean Conveyor

### FEATURES

- Made in the USA
- 304 stainless steel construction
- Extreme wash down
- Severe duty gear motor

### DESIGN HIGHLIGHTS

- Food-safe applications
- Flip clean in-feed end
- Very quiet operation
- Few spare parts
- Fast & easy cleaning
- Low operating cost
- Long lasting design

### OPTIONS

- Nema 4X VFD
- Side guides
- Full welded model
- Stainless motor and reducer
- UHMW-PE side guides
- S.S. Casters

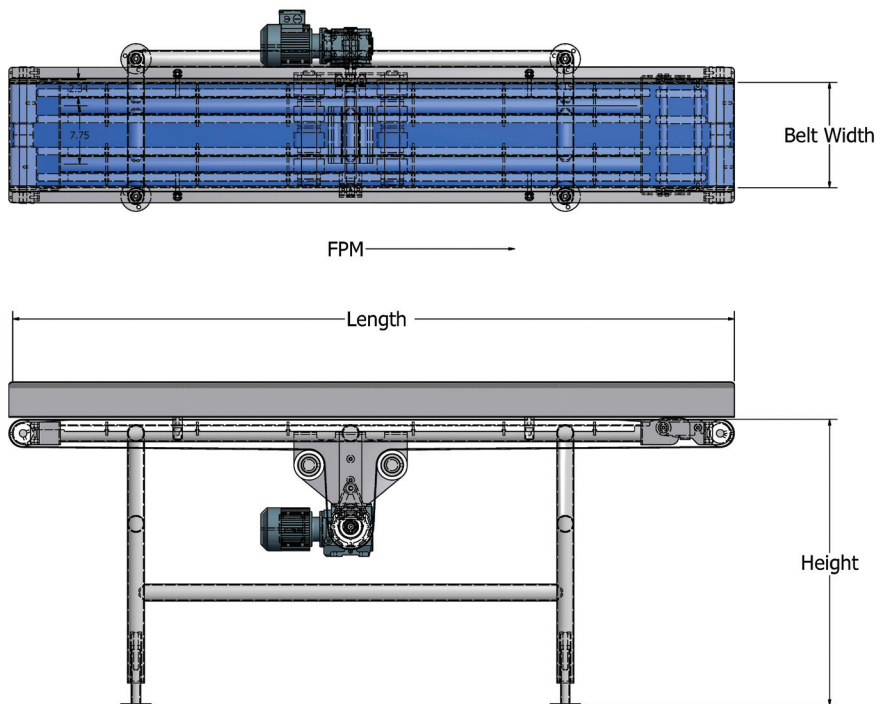

	Standard	Options
Speed	60 FPM	Variable Nema 4X VFD
Drive Location	Bottom Mount	Customer specified
Belt	Solid Urethane	Blue or white
Frame	Stainless tube	Cantilever
Drive	1/2 HP, 230/460/3/60	DC, 115 VAC, Brake motor

Eaglestone Inc.  
3705 Swenson Ave.  
St. Charles, IL 60174

Tel: 630-587-1115  
Fax: 630-587-1116  
Email: [cs@eaglestoneinc.com](mailto:cs@eaglestoneinc.com)

[www.EaglestoneEquipment.com](http://www.EaglestoneEquipment.com)



# EAGLESTONE

EQUIPMENT