

Series 1800



EAGLESTONE
EQUIPMENT

Series 1800 Metal Detector Conveyor



FEATURES

Made in the USA
304 stainless steel construction
Extreme wash down
Severe duty gear motor

DESIGN HIGHLIGHTS

Food-safe applications
Very quiet operation
Few spare parts
Fast & easy cleaning
Low operating cost
Long lasting design

OPTIONS

Nema 4X VFD
In-feed and discharge hopper
Retracting end
Diverting chute
Push off
Full welded model
Stainless motor and reducer
Side guides
S.S. Casters

Eaglestone Inc.
3705 Swenson Ave.
St. Charles, IL 60174

Tel: 630-587-1115
Fax: 630-587-1116
Email: cs@eaglestoneinc.com

www.EaglestoneEquipment.com

Metal detection for food and packaging production is essential in maintaining the highest quality control. Eaglestone's metal detector conveyor systems integrate seamlessly with existing lines and can be fitted with your choice of belt, including modular plastic or fabric belts for the sanitary production of raw products.

Eaglestone Equipment provides a full and custom range of metal detectors with varied sensitivities and detection to handle any food processing and packaging need. Our team of engineers and designers will help you decide what system is right for you, right down to designing into your current line.

- Ferrous, non-ferrous and stainless metal detection.
- Custom designed to fit your plants requirements.
- Many safety features unique to the industry, including non-enclosed bolts, easy clean rollers and more.
- Custom options of goods rejection including belt stops, pneumatic retracting belt, pushing systems, and alarms.



EAGLESTONE
EQUIPMENT

Series 1800



EAGLESTONE
EQUIPMENT

Series 1800 Metal Detector Conveyor

FEATURES

- Made in the USA
- 304 stainless steel construction
- Extreme wash down
- Severe duty gear motor

DESIGN HIGHLIGHTS

- Food-safe applications
- Very quiet operation
- Few spare parts
- Fast & easy cleaning
- Low operating cost
- Long lasting design

OPTIONS

- Nema 4X VFD
- In-feed and discharge hopper
- Retracting end
- Diverting chute
- Push off
- Full welded model
- Stainless motor and reducer
- Side guides
- S.S. Casters

Eaglestone Inc.
3705 Swenson Ave.
St. Charles, IL 60174

Tel: 630-587-1115
Fax: 630-587-1116
Email: cs@eaglestoneinc.com

www.EaglestoneEquipment.com

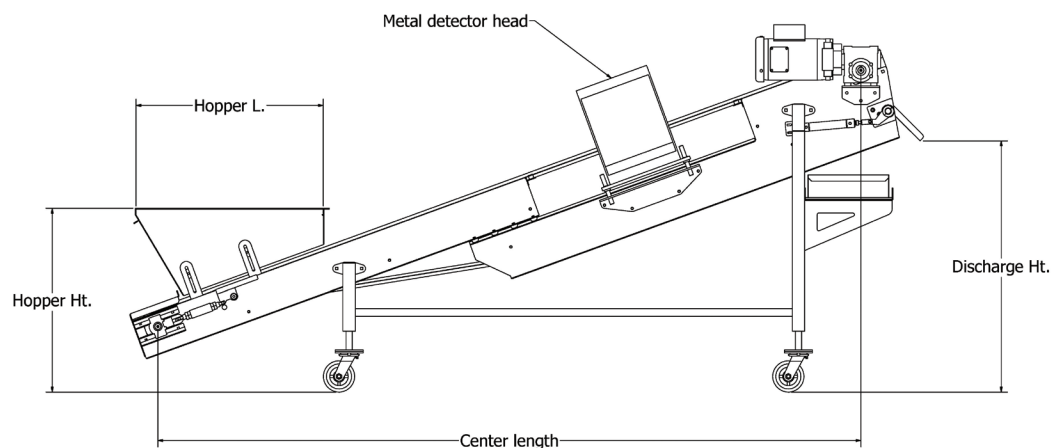
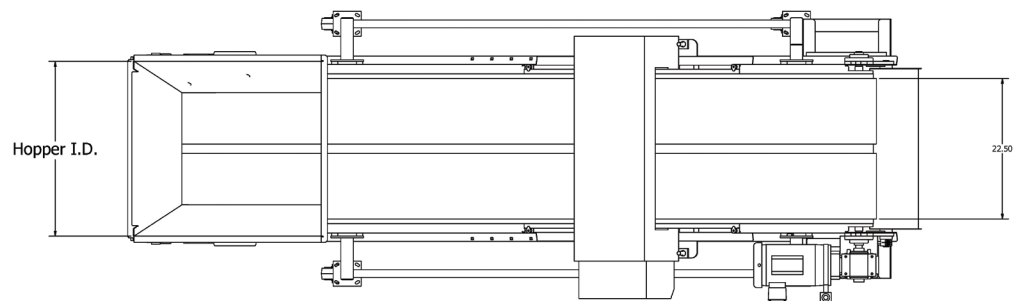

*Incline metal detector conveyor shown

	Standard	Options
Speed	60 FPM	Variable Nema 4X VFD
Drive Location	Side Mount R.H.	Customer specified
Belt	Modular plastic	Fabric, Urethane, etc
Aperture size	Customer specified	
Drive	1 HP, 230/460/3/60	DC, 115 VAC, Brake motor
Material	304 #4 polished stainless steel	Painted mild steel, aluminum
Levelers	Adjustable s.s. floor levelers	Swivel, rigid s.s. casters



EAGLESTONE
EQUIPMENT