

Series 1600



EAGLESTONE
EQUIPMENT

Series 1600 Wash Down Turntable

FEATURES

Made in the USA
304 stainless steel construction
Extreme wash down
Severe duty gear motor

DESIGN HIGHLIGHTS

Food-safe applications
Very quiet operation
Few spare parts
Fast & easy cleaning
Low operating cost
Long lasting

OPTIONS

Nema 4X VFD
Plastic top
Full welded top
Stainless motor and reducer
UHMW-PE side guides
S.S. Casters



- Custom Designed systems are available to suit individual application.
- Optional side tables, in-feed chutes, diverters and conveyor tie-ins are available on request.
- Specified cut outs in the outer rail can be accommodated to customers specifications.
- A number of different options are available.

The 1600 series wash down turntable was designed specifically for a wide range of industries: such as pharmaceutical, food manufacturing, ready meals, bottling, canning, bag pack-off and many more.

The 1600 turntable can be used for product sortation, accumulation as well as directional change.

The Eaglestone 1600 turntable is available in sizes ranging from 2' ft. diameter to 10' ft. diameter. The standard table top is 7ga (.1875") thick stainless steel with solid UHMW-PE support wheels for quiet, smooth operation.



Adjustable levelers with easy clean channel legs.

Eaglestone Inc.
3705 Swenson Ave.
St. Charles, IL 60174

Tel: 630-587-1115
Fax: 630-587-1116
Email: cs@eaglestoneinc.com

www.EaglestoneEquipment.com



EAGLESTONE
EQUIPMENT

Series 1600



EAGLESTONE

EQUIPMENT

Series 1600 Wash Down Turntable

FEATURES

- Made in the USA
- 304 stainless steel construction
- Extreme wash down
- Severe duty gear motor

DESIGN HIGHLIGHTS

- Food-safe applications
- Very quiet operation
- Few spare parts
- Fast & easy cleaning
- Low operating cost
- Long lasting

OPTIONS

- Nema 4X VFD
- Plastic top
- Full welded top
- Stainless motor and reducer
- UHMW-PE side guides
- S.S. Casters

Eaglestone Inc.
3705 Swenson Ave.
St. Charles, IL 60174

Tel: 630-587-1115
Fax: 630-587-1116
Email: cs@eaglestoneinc.com

www.EaglestoneEquipment.com

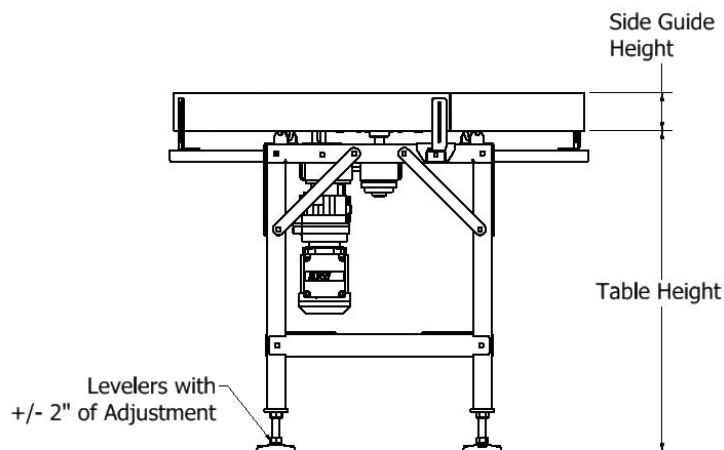
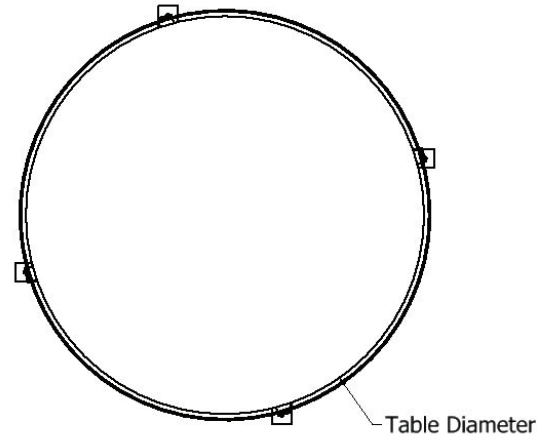

	Standard	Options
Speed	6 RPM	Variable Nema 4X VFD
Drive Location	Bottom Mount	
Table Top	7 ga (.1875") s.s. flat	Dished, plastics, etc.
Diameter	42" dia.	24" to 120"
Drive	1/2 HP, 230/460/3/60	DC, 115 VAC, Brake motor



EAGLESTONE

EQUIPMENT