

# PL-SERIES MODULAR CONVEYOR LINE

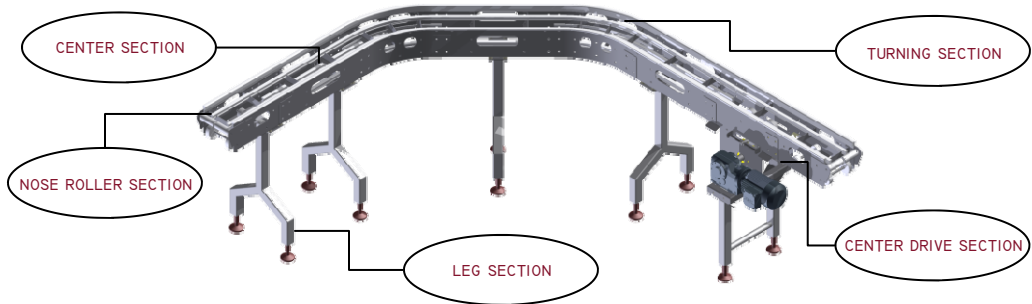

AS YOUR BUSINESS GROWS, SO DOES OUR CONVEYORS. OUR LEADING MODULAR PL-SERIES ALLOWS OUR CUSTOMERS TO ADD OR SUBTRACT PIECES TO FURTHER CUSTOMIZE MACHINES WHEN PRODUCTION CIRCUMSTANCES CHANGE.

## TECHNICAL SPECIFICATIONS

**BELTING:** MODULAR PLASTIC 1" PITCH TURNING BELT

**MATERIAL:** #4 POLISHED 304 STAINLESS STEEL

**SIDE GUIDES:** PATENT PENDING SOLID UHMW

**WEARSTRIPS:** SOLID EXTRUDED UHMW I-BEAM

**LEVELING MOUNTS:** SHOWN WITH FDA LEVELERS



# EAGLESTONE

EQUIPMENT

PHONE: (630) 587-1115

WWW.EAGLESTONEINC.COM